



**DIGITAL
DECAL**

Powered by
BEERCRAWL

Brewery Edition

CRAWLMEDIA

BREWERY MANAGED DIGITAL DECALS INSTRUCTION MANUAL

CONTENTS

For further information on each option, please click below.

OVERVIEW	2
SUPPORT & LICENCING	2
DECAL OPERATION MODES / WI-FI PREREQUISITES	3
HOW BEERS ARE ADDED TO BEER CRAWL	3
ARTWORK REQUIREMENTS FOR THE DIGITAL DECALS	4
FEATURES	5
OUR ACCESS POINTS	7
OUR PRODUCT MANAGEMENT SYSTEM	7
FACER PLATES	9
CABLE MANAGEMENT	10
REAR SCREENS	12
REAR WRITING PLATES	13

OVERVIEW

This document is for 'Brewery Managed' decals. This is for Digital Decals that are owned and managed by the brewery and put into venues. If you have Digital Decals that are for your tap room, [view this document](#)

The Brewery managed Digital Decals use different software than the standard venue managed Digital Decals. Simply put, the brewery manages what beer gets displayed on the Digital Decal, and the venue logs in to set glass sizes and pricing. The brewery also has control of if advertisement slides are used, and the content for the advertisement space. The Brewery Managed Digital Decals can also be used for Beer Festivals and the like.

CHECK OUT PROMO VIDEO ON [YOUTUBE](#) 

BREWERY SIDE SETUP / MANAGEMENT:

1. Log in to beer Crawl and select your 'brewery' listing.
2. On the left hand menu, select 'Digital Decals'.
3. Click the cog next to the relevant digital decal.
You can use the search field to filter by the Digital Decals serial number, venue name and tap number.
Note, We need to assign a Digital Decal to your brewery. If one is not listed, please contact us.
4. A pop up will appear, click "edit venue, Tap & Beer.
5. On this new page.
 - a. On venue: type in the venues name, wait and select.
If the venue is not listed in Beer Crawl, please email us the details so we can promptly add it.
 - b. Select the tap number that the decal will be assigned to.
 - c. Select the beer you want to display on the decal.
 - d. Click save.

Your Brewery managed Decal is now set.

VENUE SIDE SETUP / MANAGEMENT:

1. Log in to beer Crawl and select the venue listing (that the decal is assigned to).
2. On the left hand menu, select 'Digital Decals'.
3. Click the cog next to the relevant digital decal.
You can use the search field to filter by the Digital Decals serial number and brewery name name and tap number.
4. A pop up will appear, click "edit".
5. Add pricing.
If the venue has not setup what glass sizes they serve, click 'glass sizes on the left hand menu to add, then repeat from step 2.

It is important that we receive the relevant contact information (name / email / phone number) for the recipient venue. We will only contact them to allow access to Beer Crawl so they can manage the pricing listed on the Digital Decals and support.

SUPPORT & LICENCING

The Decals are used for two applications:

1. The tap / decal shows a 'locked' beer.

Although the beer can change, it is a permanent / semi permanent beer on the tap/decal. **The Licencing is only required for this application when content requires changes.**

2. The tap / decal changes beers frequently.

Licencing is required for this application.

We have a state-of-the-art management system allowing you to control content on the digital decal 24/7 anywhere in the world (with internet). This allows updating image or video for the beer graphic / advertisements / pricing and whole lot more. Licencing for the decals SaaS system is based per tap / month. The monthly licencing fee is only required if you want access to these features.

Only want to use the decals to promote full screen video of a 'core' / locked / not changing beer - or for trade shows or festivals? No problems! Simply only activate the license when you need to update them!

We offer tiered discounts, contact us for formal quote.

DECAL OPERATION MODES / WI-FI PREREQUISITES

The Digital Decals have been designed to work in two scenarios

1. WITHOUT WI-FI INTERNET: For Decals displaying a 'locked beer'

The decal only requires internet to load the beer. Once loaded the decal can operate indefinitely without internet. Wi-Fi is only required in order to update content.

We can ship the decal to you with the beer / content preloaded, or, you connect the decal to internet and update content (requires licencing).

2. WITH WI-FI - For Decals displaying frequently changing beers, or content

If content updating is required for the Digital Decals, the venues Wi-Fi infrastructure must meet our requirements.

[Click here](#) for more info. If the requirements are too problematic for a venue, use of our pre-configured Access Points is required.

HOW BEERS ARE ADDED TO BEER CRAWL

Beers are managed by the brewery direct, venues* (if the beer has not been listed by the brewery) and Beer Crawl staff.

General users of Beer Crawl can 'report' a beer, however, due to our tenet of accuracy of information, these reported beers do not get listed to the brewery without Beer Crawl's (or the Breweries) manual approval.

Venues on the other hand, have more of a vested interest to supply accurate information than a 'general user'. Due to this, when a venue creates a 'custom beer' and selects a brewery, it is added to that brewery's beer list.

All Beers that are added to a brewery can be managed by the brewery. Some features include:

- Updating
- Marked Active or Inactive.
- Flagged as 'core range', 'Seasonal', 'Limited release', 'Gluten reduced', 'Gluten 100% free' and 'Discontinued'
- Update description and Sales notes (that get displayed on the 'Rear Decals')
- Manage / update decal images
- Add collaboration breweries

'LOCK CONTENT': Breweries can opt for '**Lock Content**' meaning only requested employees of the brewery can create / add beers to their brewery. If this is activated, if a venue creates a beer and tries to assign it to the specific brewery, an error message of "*This brewery has forbidden venues to create a beer on their behalf. Please contact the brewery to create this beer*" shows.

FOR **BREWERY** INSTRUCTIONS TO ADD BEER [CLICK HERE](#) OR CHECK IT OUT ON 

FOR **VENUE** INSTRUCTIONS TO ADD BEER [CLICK HERE](#) OR CHECK IT OUT ON 

ARTWORK REQUIREMENTS FOR THE DIGITAL DECALS

The Digital Decals have been designed from the ground up to supply a feature-packed product at minimal cost. The Digital Decals can display generic decal artwork, photos and animation.

NOTE FILE SIZE LIMIT = 30 MB. Compression is used after upload to optimise delivery and play performance.

Prefer to see this online? [Click here](#)

Decal artwork is displayed in two formats:

1. **Standard / Square:** This is displayed throughout Live Menu & Beer Crawl.
2. **Full Screen – Rectangle:** This is displayed on an optional view on our Digital Decals. This gives more brand activation when the decals are located further away from the patron (this comes at the cost of not displaying the beer/pricing information on the bottom half of the decal).

MAX FILE SIZE: 30 MB. Compression is used after upload to optimise delivery and play performance.

Standard / Square

STATIC STILL IMAGES

- **ASPECT RATIO:** MUST BE SQUARE (1:1 aspect ratio) – *Uploading other sizes may cause cropping.*
- **FILE FORMAT:** JPG, GIF or transparent PNGs
- **RESOLUTION:** 1080 x 1080 px or above

ANIMATED DECAL ART

- **ASPECT RATIO:** MUST BE SQUARE (1:1 aspect ratio) – *Uploading other sizes will cause cropping.*
- **FILE FORMAT:** .MP4 or animated GIF
- **RESOLUTION:** 1080 x 1080 px or above
- **FPS:** 24
- **DURATION :** 15 seconds (MAX)

Full Screen / Rectangle

Please note 'Full Screen' images are being integrated into the Decals. This function will be released with ETA March / April 2023. In the meantime, please email these images through for manual integration.

STATIC STILL IMAGES

- **ASPECT RATIO:** Rectangle (9:16 aspect ratio) – *Uploading other sizes will cause cropping.*
- **FILE FORMAT:** JPG, GIF or transparent PNGs
- **RESOLUTION:** 1440 x 2560 px or above

ANIMATED DECAL ART

- **ASPECT RATIO:** Rectangle (9:16 aspect ratio) – *Uploading other sizes will cause cropping.*
- **FILE FORMAT:** .MP4 or animated GIF
- **RESOLUTION:** 1440 x 2560 px or above
- **FPS:** 24
- **DURATION :** 20 seconds (MAX)

By default, the beer artwork will be branded with your brewery's logo. This allows your beer to be 'featured' in prominence on **TV screens** and to display crisp on our **Digital Decals**. We also recommend 'decal artwork' to be uploaded as transparent PNG as the decals will be displayed on both light, dark and image backgrounds.

FEATURES

Our feature-packed Digital Decals are designed to accommodate future technologies. This is a list of current options/features. Note a paid Beer Crawl subscription is required.

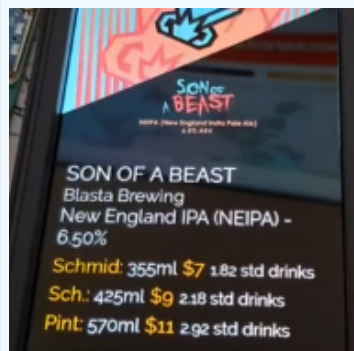

BEER DETAIL

The main screen is split into two sections:

TOP: shows the decal artwork. (Brewery Manged)

BOTTOM: displays beer name / brewery / Beer Style. (Brewery Manged)

It then shows prices & standard drinks based on the size of glasses your venue has. (Venue Manged)



BEER PRICING

Prices are updated in your Beer Crawl account with optional extras:

- Happy Hour pricing (add happy hours times and at % or \$ discount) then simply tick the tick box to enable or disable
- Public holiday surcharge (add % or \$ surcharge) then simply tick the tick box to enable or disable
- Member pricing (Venue Manged)

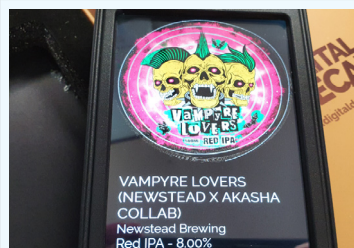

ANIMATED DECAL ARTWORK

The next generation in beer promotion. Animated decals.

Check these examples out:

[Flower Power](#) Animated GIF artwork created by [Clear Design Studio](#)

(Brewery Manged)



IN-HOUSE PROMOTIONS / ADVERT SPACE

- Get your in-house promotions seen in the best position in the venue
- On-sell advertising space – INSANELY good ROI
- Simply upload image (1440 x 1060px) and click save to display
- Supports multiple slides
- 7 second rotation (price > advert > price > advert 2 etc)

Simply go to [digital decals](#) tab and scroll to the bottom.

Upload image then click save. To add additional slide simply click the '+' icon -

Note you may have to refresh after uploading image.

You can enable / disable the advert via a tick box.

(Brewery Manged)



BEER TEMPORARILY UNAVAILABLE

This is displayed either when a beer has been removed or when a beer runs out that is assigned to a permanent tap.

An overlay image is displayed so customers know the beer will be back soon.

Simply use go to [beer tab](#) > [click cog next to beer](#) > [edit](#) >

[click 'Beer Unavailable'](#) > [click save at bottom](#).

Simply un-tick when the beer is back or assign another beer to the tap.

(Venue Manged)

	<p>INTERNET DROP-OUT</p> <p>If internet drops out, a red 'no internet' bar will display. As soon as internet is picked back up, the message will automatically disappear and resume price and advert content. The screen will have a slight opaque darkness over it to better show the 'no internet' message. The Decal will automatically power cycle if internet is out for more than 2 hours.</p>
	<p>CACHED CONTENT</p> <p>On bootup, if The Digital Decal does not have internet, after 15 minutes, it will display the last loaded beer and pricing. Note without internet, the decal cannot update content.</p> <p>IMPORTANT NOTE If the Digital Decal has no internet with more than 30 boot cycles 'subscription lapsed' will show. This is a licensing system that prevents the Digital Decal to be used indefinitely without checking for active licence. Keep in mind the Digital Decal does an automated daily power cycle between 8:45 to 9:15am</p>
	<p>POWER SAVING MODE</p> <p>The Decals are placed into a power saving mode depending on your venues hours. See further notes on the 'Digital Decal' tab in your Beer Crawl venue management. This increases the life of the LCD panel and saves on electricity costs.</p>
	<p>POWER CYCLING</p> <p>The Decal will automatically power cycle between 8:45 and 9:15 am daily. WE RECOMMEND leaving the decals on to allow software updates and Wi-Fi status logging.</p>
	<p>OVER THE AIR UPDATES</p> <p>As long as the Decal has Wi-Fi, it can receive software updates. These can include bug fixes and security patches.</p>
	<p>QR CODE</p> <p>Click one button to toggle QR code on the decal. Displayed in the bottom section as a 7 second slide, it allows customers to quickly scan and see all specs and tasting notes of the beer. (Brewery Manged)</p>
	<p>NEW BEER COMING SOON</p> <p>If no beer is assigned to a tap, this message will appear. It is automatically removed as soon as a beer is reassigned to the tap. (Venue Manged)</p>

OUR ACCESS POINTS

If you need want a stress-free solution without potential assistance from your I.T. Provider / venues I.T., the simplest solution to provide internet to the Digital Decals is one of our pre-configured Access Points (APs). The access point has a key installed so the decals will automatically connect, meaning setup is not required to connect to the internet with the decal. Furthermore, as we have a Unify cloud controller account, we can provide more remote assistance like remotely rebooting the AP which can clear the most common Wi-Fi conflicts.



NOTE: This is the Quickest and most secure option and the easiest to manage.
If there is excessive Wi-Fi noise in the area, this can still be problematic but quicker to resolve.

OUR PRODUCT MANAGEMENT SYSTEM

We have developed a state-of-the-art product management system. This is to quickly identify any potential internet connection issues or product faults. Although we do not connect to any of the venues connected devices (for obvious privacy and security reasons), we can 'ping' internet infrastructure equipment and perform tests on the Digital Decals.

ID	Decal ID	OS Version	App Version	Licensed?	Venue	Beer	Tap #	Last Heard From	Last Link Quality	# Dropouts	Sale Date
135	DD-SS-0000005	2.0.48	1.0.8171.32311	Y		Rogers'	12	2022-08-21 11:29:51	100	82	2022-07-16
147	DD-SS-0000017	2.0.48	1.0.8171.32311	Y		Tropical Lager	5	2022-08-21 09:39:55	99	311	2022-07-16
148	DD-SS-0000018	2.0.48	1.0.8171.32311	Y		Larry	8	2022-08-21 11:29:48	100	107	2022-07-16

Online Status:

This quickly identifies the connection status of the decals. There are two separate processes that operate on the Digital Decal and communicate with Beer Crawl.
Process 1: retrieves data and draws on the screen – it checks for data every 6 seconds.
Process 2: receives update instructions from Beer Crawl and performs them on the decal.

RED: we have not heard from either of these services for **2 minutes**. This means we CANNOT remote power-cycle. IF restarting is required, it must be done manually by the venue.

ORANGE: Successful communication for process 2 but not process 1 (**within 4 minutes**).

GREEN: Confirmed connection.

Online Status	Decal ID	Tap Number	Connection
	DD-SS-0000014	1	Wifi: Digit: [blurred]
	DD-SS-0000135	2	Wifi: Digital [blurred]
	DD-SS-0000104	3	Wifi: Digit: [blurred]
	DD-SS-0000119	4	Wifi: Digital [blurred]
	DD-SS-0000017	5	Wifi: Digit: [blurred]

Connection:

Our product management system allows us to see what SSID each Digital Decal is currently connected to. This allows us to quickly see if the decals are connected to a different/ potentially problematic Access Point (AP)

Basic Decal Management

In this view we can:

- Reset recorded number of dropouts (to test if wireless infrastructure has changed at the venue and to compare)
- See history of what SSID the Digital Decals have connected to.
- Flip the screen of the decals (if the Digital Decals are placed upside down)
- See Sales / Install date to quickly identify warranty status.

Edit Notes Logs Requested Stats

Decal ID * DD-SS-000097 Flip Screen

Venue (select to get tap list) North Lakes Sports Club Unflip Screen

Venue Tap Tap code - 18691 - North Lakes Sports Club - Tap 1 Recorded number of dropouts since 21/01/2022 @ 16:28 **302** Reset

BREWERY ONLY

Managing Brewery (leave blank to let venue manage tap) Last Wifi change: 21/08/2022 @ 09:06

Beer on tap Hop Swap (India Pale Ale (IPA)) (6.80%)

Date of sale 16/07/2022

Pull Decal Logs:

If the decal has internet connection, at the click of a button, we can pull detailed logs from the decal. This can assist us to establish 'Wireless Noise' at the venue and check for problematic setups with the venues wireless infrastructure.

Edit Notes Logs Requested Stats

Get decal logs

```

Aug 21 11:01:53 Digital-Decal-DD-SS-000097 mgd[456]: stats: FIPS 140-2 failures: 0
Aug 21 11:01:53 Digital-Decal-DD-SS-000097 mgd[456]: stats: FIPS 140-2(2001-10-10) Monobit: 0
Aug 21 11:01:53 Digital-Decal-DD-SS-000097 mgd[456]: stats: FIPS 140-2(2001-10-10) Poker: 0
Aug 21 11:01:53 Digital-Decal-DD-SS-000097 mgd[456]: stats: FIPS 140-2(2001-10-10) Runs: 0
Aug 21 11:01:53 Digital-Decal-DD-SS-000097 mgd[456]: stats: FIPS 140-2(2001-10-10) Long run: 0
Aug 21 11:01:53 Digital-Decal-DD-SS-000097 mgd[456]: stats: FIPS 140-2(2001-10-10) Continuous run: 0
Aug 21 11:01:53 Digital-Decal-DD-SS-000097 mgd[456]: stats: HRNG source speed: (min=85.535; avg=198.753; max=1012.087)Kibits/s
Aug 21 11:01:53 Digital-Decal-DD-SS-000097 mgd[456]: stats: FIPS tests speed: (min=31.064; avg=33.908; max=36.964)Mibits/s
Aug 21 11:01:53 Digital-Decal-DD-SS-000097 mgd[456]: stats: Lowest ready-buffers level: 2
Aug 21 11:01:53 Digital-Decal-DD-SS-000097 mgd[456]: stats: Entropy starvations: 0
Aug 21 11:01:53 Digital-Decal-DD-SS-000097 mgd[456]: stats: Time spent starving for entropy: (min=0; avg=0.000; max=0)us
Aug 21 11:15:15 Digital-Decal-DD-SS-000097 systemd[1]: Starting Reboot on network failure...
Aug 21 11:15:19 Digital-Decal-DD-SS-000097 systemd[1]: reboot-on-network-failure.service: Succeeded.
Aug 21 11:15:19 Digital-Decal-DD-SS-000097 systemd[1]: Finished Reboot on network failure.
Aug 21 11:17:01 Digital-Decal-DD-SS-000097 CRON[1395]: pam_unix(cron:session): session opened for user root(uid=0) by (uid=0)
Aug 21 11:17:01 Digital-Decal-DD-SS-000097 CRON[1396]: (root) CMD ( cd / && run-parts --report /etc/cron.hourly)
Aug 21 11:17:01 Digital-Decal-DD-SS-000097 CRON[1395]: pam_unix(cron:session): session closed for user root
Aug 21 11:19:04 Digital-Decal-DD-SS-000097 wpa_supplicant[385]: wlan0: CTRL-EVENT-SIGNAL-CHANGE above=0 signal=-77 noise=9999 txrate=39000
Aug 21 11:19:10 Digital-Decal-DD-SS-000097 wpa_supplicant[385]: wlan0: CTRL-EVENT-SIGNAL-CHANGE above=1 signal=-66 noise=9999 txrate=39000
  
```

Request Decal Stats:

We have a list of processes that can be performed at the click of a button. Some of these features require the Decal to have internet, others are a running log.

Edit Notes Logs Requested Stats

Show 25 entries

Stat Name	Description	Total Number Recorded	Queue Stat Request
Drop out/in	Indicates times decals turned red. created at being the time connection was lost, and updated the time it returned.	302	

Show 10 entries

Sample Date	Created	Updated
2022-08-20 21:16:01	2022-08-20 18:33:02	2022-08-20 21:16:01
2022-08-20 17:04:02	2022-08-20 17:01:02	2022-08-20 17:04:02
2022-08-20 09:16:16	2022-08-20 09:12:02	2022-08-20 09:16:16
2022-08-16 05:19:17	2022-08-16 04:20:15	2022-08-16 05:19:17
2022-08-15 10:58:01	2022-08-15 10:57:02	2022-08-15 10:58:01
2022-08-15 10:47:02	2022-08-14 15:49:02	2022-08-15 10:47:02
2022-08-14 14:47:02	2022-08-14 11:40:17	2022-08-14 14:47:02
2022-08-13 23:30:20	2022-08-13 23:28:07	2022-08-13 23:30:20
2022-08-13 23:10:18	2022-08-13 20:23:02	2022-08-13 23:10:18
2022-08-13 19:36:02	2022-08-13 19:31:02	2022-08-13 19:36:02

Showing 1 to 10 of 50 entries





Stat Name	Description	Total Number Recorded	Request Stat
General quality of the reception		0	Request Stat
Signal strength at the receiver		0	Request Stat
Screen Power State changes		1	
Take screenshot of decal		0	Request Stat
Take a snapshot of current contents of decal's working folders		0	Request Stat
10-second MTR test		0	Request Stat
100-second MTR test		0	Request Stat
1,000-second MTR test		0	Request Stat
10-second download test		0	Request Stat
100-second download test		0	Request Stat
1,000-second download test		0	Request Stat
10 second upload test		0	Request Stat
100 second upload test		0	Request Stat
1,000-second upload test		0	Request Stat

FACER PLATES



The Digital Decal casing is constructed by injection moulded ABS. The finish is matt black. We have taken this one step further to allow customisation for the Digital Decals – Facer Plates. Available in an array of materials from real wood to acrylic. The benefit is you can customise the decals to your venue – AND brand them with your logo.

MATERIAL SELECTION:

	BRUSHED SILVER <i>duets range</i>		BRUSHED GOLD <i>duets range</i>
	BRUSHED COPPER <i>duets range</i>		BLACK WALNUT ON WHITE <i>duets range</i>

Contact us for additional customised finishes

CABLE MANAGEMENT

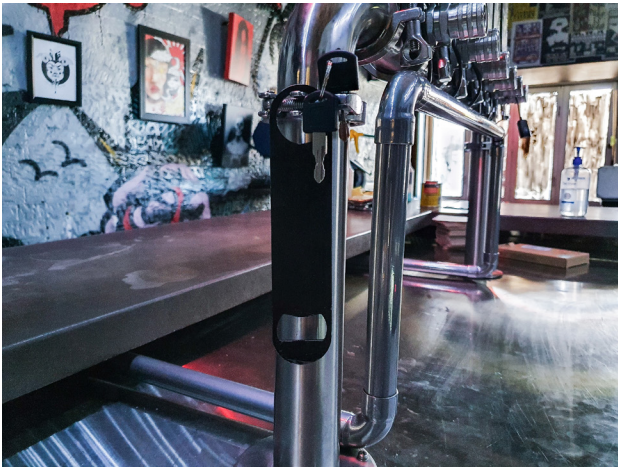

The Digital Decals are powered by low voltage USBC cables.

Some client choose to attach the cables via cable ties, others to drill holes into their fonts, others prefer a surface-mounted option.

CABLE-TIED EXAMPLE:



SURFACE MOUNTED - FONT TYPES:

We provide a surface-mounted option which is custom cut to suit your font.

Made from 25mm aluminium tube then powder coated, they look the part, durable and easy to install.

1. Type of Font: 'T-BAR' or 'GOAL POST' or 'LADDER'



2. Length of your font - Measure the horizontal length of your font.

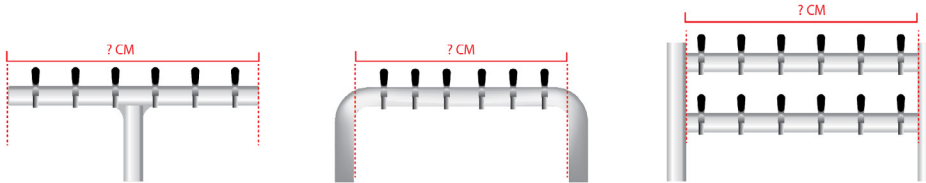

3. Heights of fonts

T-BAR & GOAL POST: Height from surface of bar to tap centre (where taps connect)

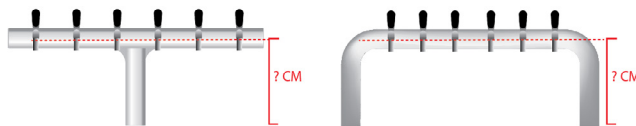

LADDER:

Note: brackets and a modified version of the decal is required for Ladder style fonts.

- a. Height from surface of bar to tap centre of bottom rung
- b. Height between tap centre of bottom and top rung
- c. Height between tap centre and top of bottom rung tube
- d. Distance between where Decal is mounted and clearance of front of top rung tube

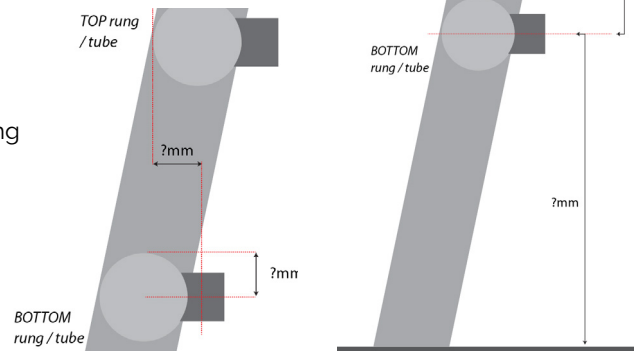

POWDER COATING COLOUR OPTIONS:

The cable management system is available in the following finishings:

	COPPER PATINA
	SATIN BLACK
	CHROME
	POLISHED BRASS (GOLD)

Contact us for customised finishes.

REAR SCREENS

The rear decals have been made as a modular add-on. The rear decals are to display information to the bar staff. With the release of the V2 decals, the rear screen is now an optional upgrade to the Digital Decal. *Previously the rear decal was a separate product.*

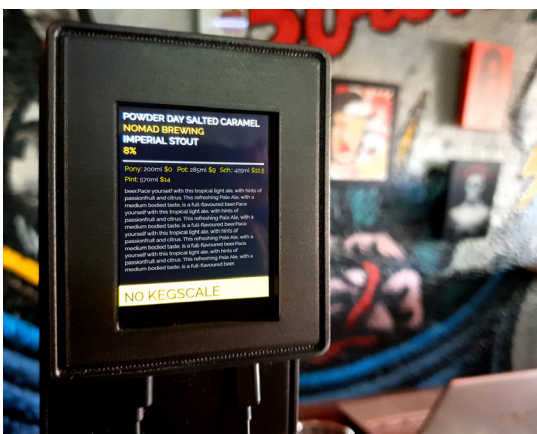
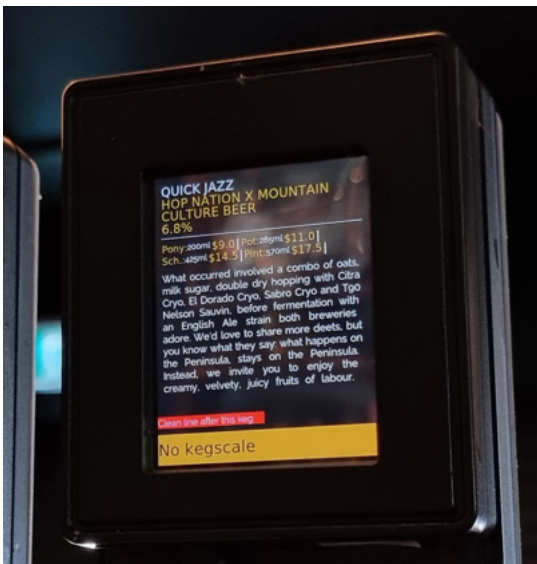

CUSTOM NOTES

Use tasting notes as supplied by the brewery or add your own. *Just go to the edit beer where you add pricing to see options*

- Option to show pricing

DYNAMIC SIZING

The description text size is dynamic: The less text, the larger the writing will display

DISPLAY KEG VOLUME

Shows remaining volume left in keg

- Requires our [Keg Scales](#)
- If kegscale is not connected it will show 'no kegscale'

CLEAN BEER LINE Clean line after this keg

Add a notification flag to show staff that the individual beer line needs to be cleaned after the keg is finished.

NO SAMPLES NO samples

Add a notification flag to show staff that no samples should be given for the individual beer.

SHOW PRICING

Toggle show / hide pricing.

REAR WRITING PLATES

If you don't intend on using our 'rear screen', this is the product for you.

Available in white or black acrylic, these gloss plates allow you to quickly write beer info on the back of the decals. Use a white board marker or liquid chalk pen, and you can effortlessly change details when the beer changes.



On black gloss acrylic, use [Liquid Chalk Marker](#)

ANY ISSUES?

See the [troubleshooting document](#) [here](#)

Email support22@crawlmedia.com.au

Easier to chat? Supply your phone number and we will promptly call back

